

ex-4/4



NATIONAL INSTITUTE FOR RESEARCH,
DEVELOPMENT AND TESTING
ELECTRICAL ENGINEERING
ICMET CRAIOVA



High Voltage Division - HVD
High Voltage Testing and Electromagnetic Compatibility Laboratory
LIT - CEM

Bvd. Decebal No.118A, 200746 Craiova, ROMÂNIA
Phone: + 40 0351 402425, 404888; Fax: + 40 0351 404890
www.icmet.ro, e-mail: market@icmet.ro

TEST REPORT

No. 44316 / 04.08.2014

- CUSTOMER: FOREND Elektrik Malz. Ve Dis Tic. A.S.**
Address: Halaskargazi cad. No. 141 K: 4/7 Osmanbey – Sisli – Istanbul TURKEY
- MANUFACTURER: FOREND Elektrik Malz. Ve Dis Tic. A.S.**
Address: Halaskargazi cad. No. 141 K: 4/7 Osmanbey – Sisli – Istanbul TURKEY
- TESTED PRODUCT: Early Streamer Emission Lightning Conductor (E.S.E.L.C.) type FOREND EU**
Serial no.: prototype
- REFERENCE STANDARD: NFC 17-102 : 2011 Annex C; UNE 21186 : 2011, Annex C**
- TEST PERFORMED: Early streamer emission tests**
- TEST DATE: 01.08.2014**
- TEST RESULTS: There are presented the determined results.**
- The report contains: 14 pages**
- The test report is edited in 4 copies, copy no.1 remain in laboratory and copies 2, 3 and 4 are sent to the customer.**

HEAD OF HV DIVISION
Eng. MIHAI George



HEAD OF LABORATORY
Eng. BADEA Ion



- Results refer to the tested product only.
- Publication or reproduction of the contents of this report in any other form unless its complete photocopying is not allowed without writing approval of Division to which laboratory belongs.
- All signatures of the present report are original ones.



HVD

Content	page
➤ Identification of the test product	3
➤ Tests program	3
➤ Responsible for tests	3
➤ Opinions and interpretation (if necessary)	3
➤ Present at the tests	3
➤ Tested material	4
➤ Type of tests	4
➤ Specification	3
➤ Test equipment	4
➤ Test circuit	4
➤ Mounting arrangement	5
➤ Test procedure	5
➤ Test on simple rod lightning conductor (S.R.L.C.)	6
➤ Test on early streamer emission lightning conductor (E.S.E.L.C.) type FOREND UE	7
➤ Table with measuring results on S.R.L.C.	8
➤ Table with measuring results on E.S.E.L.C. type FOREND EU	9
➤ Graphic determination of the E.S.E.L.C. type FOREND EU efficiency	10
➤ Photos	11
➤ Test circuit diagram	12
➤ Test set-up on early streamer	13
➤ Drawing	14



HVD

1. IDENTIFICATION OF THE TEST PRODUCT:

Type: FOREND EU Early Streamer Emission Lightning Conductor

Serial / year: prototype / 2014

Technical Specification / Drawing: - / see page 14

Contract client: 8236 / 23.06.2014

Internal test order: 22451 / 24.06.2014

Product receiving date: 20.06.2014

Product condition at receiving: New

2. TEST PROGRAM: Early streamer emission tests

3. RESPONSIBLE FOR TEST: Eng. Mircea BORUZ

4. OPINIONS AND INTERPRETATION (IF NECESSARY):

5. PRESENT AT THE TEST:



HVD

1. Tested material

Early Streamer Emission Lightning Conductor type FOREND EU

See photo on page 11 and drawing on page 13.

2. Type of tests

A switching impulse wave having negative polarity and a DC voltage also of negative polarity were applied on the upper metallic plane.

3. Specification

NFC 17-102 : 2011 Annex C

UNE 21186 : 2011, Annex C

4. Test equipment

Laboratory inner dimensions: 48 m x 32 m x 27 m (height)

Altitude: 100 m above sea level

4200 kV High Voltage Impulse Generator type SPF 340; 340 kW, TUR
Dresden - Germany

1000 kV Rectifier cascade type GS 1000 / 30; 30 mA; TUR Dresden – Germany

1400 kV Damped capacitive divider, ICMET Craiova, Romania;

TR – AS Transient – Recorder, Dr. Strauss System Elektronik, GmbH- Germany

Digital multimeter Keithley, serial no. 1070037 – USA.

5. Test circuit

See the test circuit diagram on page 12.

The measuring system consists of:

- 1400 kV damped capacitive divider, calibration certificate DKD-K-18701 / 12.2011, no. 278;
- Transient recorder, TR - AS 100 - 10 / 4, calibration certificate D- K-15205-01-00, no. 633 / 2012.05;
- DC measuring system that consists of DC resistive divider and digital multimeter type Keithley, calibration certificate DKD - K - 18701, no. 211 / 2010-06.

The expanded uncertainties of the measuring systems are inside the limits prescribed by IEC 60060 – 2 / 2010 for SI Approved Measuring Systems (3 % for peak values and 10 % for time parameters).



HVD

6. Mounting arrangement

See the test set up on page 13

See photo on the pages 11

The tested lightning conductor was set on a 5 x 5 m grounded metallic plane and connected to ground.

A square metallic plane with dimensions: 4.5 m / 4.5 m / 0.2 m having the edges rounded, was suspended above the lightning conductor and connected to the high voltage source.

7. Test procedure

The DC polarization voltage was applied on an upper square metallic plane.

The negative impulse wave was adjusted in order to obtain a flashover.

The height of the lightning conductor (h) and the distance between the ground and the square plane (H) were measured at the beginning of each test.

The atmospheric conditions were taken at the beginning, at the middle and at the end of each test.

The peak value (U_p) of the impulses and the triggering time (T_B) were recorded for each impulse.

The early streamer emission lightning conductor (E.S.E.L.C.) is to be compared with a simple rod lightning conductor (SRLC).

Tests were performed in the same conditions and configuration for each lightning conductor: E.S.E.L.C. and S.R.L.C.

First, there were applied 50 impulses on the S.R.L.C. and after that 50 more impulses were applied on the E.S.E.L.C. type FOREND EU.

Height of lightning conductor (h) adjusted to:	1182 mm
Distance between ground / square plane (H) adjusted to:	2450 mm
h / H:	0.482
Polarization voltage:	54.5 kV
Peak time / Rise time of the full wave:	289 μ s / 367 μ s
Time interval between consecutive impulses:	2 min



HVD

8. TEST ON S.R.L.C.

8.1. Test date: 01.08.2014

8.2. Atmospheric conditions

BEFORE TEST	p = 1000 mb t = 23 °C hr = 60.2 %
MIDDLE OF THE TEST	p = 1000 mb t = 23.1 °C hr = 60.1 %
END OF THE TEST	p = 1000 mb t = 23.4 °C hr = 60 %

8.3. Results

See tables on page 8

Number of significant impulses: 50

The average value of significant break-down times (T_B) calculated from the experimental results is $T_{SRLC} = 170.92 \mu s$ with a standard deviation $\sigma_{SRLC} = 19.46 \%$.

By transferring T_{SRLC} on the reference waveform it was obtained $T'_{SRLC} = 214.83 \mu s$

See curves on page 10



9. TEST ON E.S.E.L.C. type: FOREND EU

9.1. Reception date: 20.06.2014

9.2. Test date: 01.08.2014

9.3. Atmospheric conditions

BEFORE TEST	p = 999 mb t = 23.4 °C hr = 59.9 %
MIDDLE OF THE TEST	p = 999 mb t = 23.4 °C hr = 59.7 %
END OF THE TEST	p = 999 mb t = 23.5 °C hr = 59.7 %

9.4. Results

See tables on page 9

Number of significant impulses: 50

The average value of significant break-down times (T_B) calculated from the experimental results is $T_{ESEL C} = 127.25 \mu s$ with a standard deviation $\sigma_{ESEL C} = 10.12 \%$.

By transferring $T_{ESEL C}$ on the reference waveform it was obtained $T^*_{ESEL C} = 150.34 \mu s$

See curves on page 10

Measuring uncertainty for ΔT is 5.7 %.

The uncertainty stated is expanded uncertainty obtained by multiplying the standard uncertainty by the coverage factor $k = 2$. The value of measurand lies within the assigned range of values with probability of 95 %.

Triggering advance: $\Delta T = T_{SRL C} - T^*_{ESEL C} = 214.83 - 150.34 = 64.49 \mu s \pm 3.68 \mu s$

The tested lightning conductor is an E.S.E.A.T. (early streamer emission air terminal) because it fulfils the following conditions (according to NFC 17-102 / 2011, Annex C, clause C.3.5.2.5):

- $T_{ESEL C} < T_{SRL C}$ ($127.25 < 170.92$);
- $\sigma_{ESEL C} < 0.8 \sigma_{SRL C}$ ($10.12 < 0.8 \cdot 19.46$);
- $T_{SRL C} - T_{ESEL C} > 10 \mu s$.



HVD

Test on S.R.L.C .

Impulse no.	T_B μ s	Impulse no.	T_B μ s
1	165,00	41	165,80
2	177,60	42	184,00
3	168,60	43	247,20
4	154,60	44	131,40
5	151,40	45	145,10
6	154,40	46	166,70
7	148,60	47	131,40
8	179,20	48	192,90
9	166,70	49	166,00
10	165,60	50	236,00
11	120,00		
12	154,40		
13	112,20		
14	151,60		
15	178,80		
16	172,50		
17	177,50		
18	130,20		
19	158,60		
20	176,80		
21	189,80		
22	158,80		
23	130,20		
24	259,40		
25	153,60		
26	151,60		
27	227,70		
28	233,10		
29	212,20		
30	243,30		
31	201,10		
32	146,60		
33	193,70		
34	179,90		
35	167,50		
36	165,80		
37	141,30		
38	138,20		
39	146,40		
40	174,80		

T_B : Break-down time



HVD

Test on E.S.E.L.C. type: FOREND EU

Impulse no.	T_B μ s	Impulse no.	T_B μ s
1	136,40	41	145,00
2	122,00	42	133,00
3	125,00	43	133,90
4	132,40	44	113,00
5	127,40	45	134,30
6	131,40	46	118,90
7	110,00	47	111,00
8	137,00	48	132,20
9	138,00	49	130,90
10	130,00	50	124,10
11	103,60		
12	107,00		
13	126,30		
14	140,30		
15	140,40		
16	126,20		
17	147,30		
18	135,00		
19	124,20		
20	109,00		
21	98,80		
22	117,00		
23	134,30		
24	151,60		
25	133,30		
26	126,20		
27	117,00		
28	147,00		
29	110,00		
30	114,00		
31	106,20		
32	129,00		
33	129,40		
34	112,00		
35	146,40		
36	127,00		
37	119,00		
38	136,30		
39	132,90		
40	150,00		

T_B : Break-down time

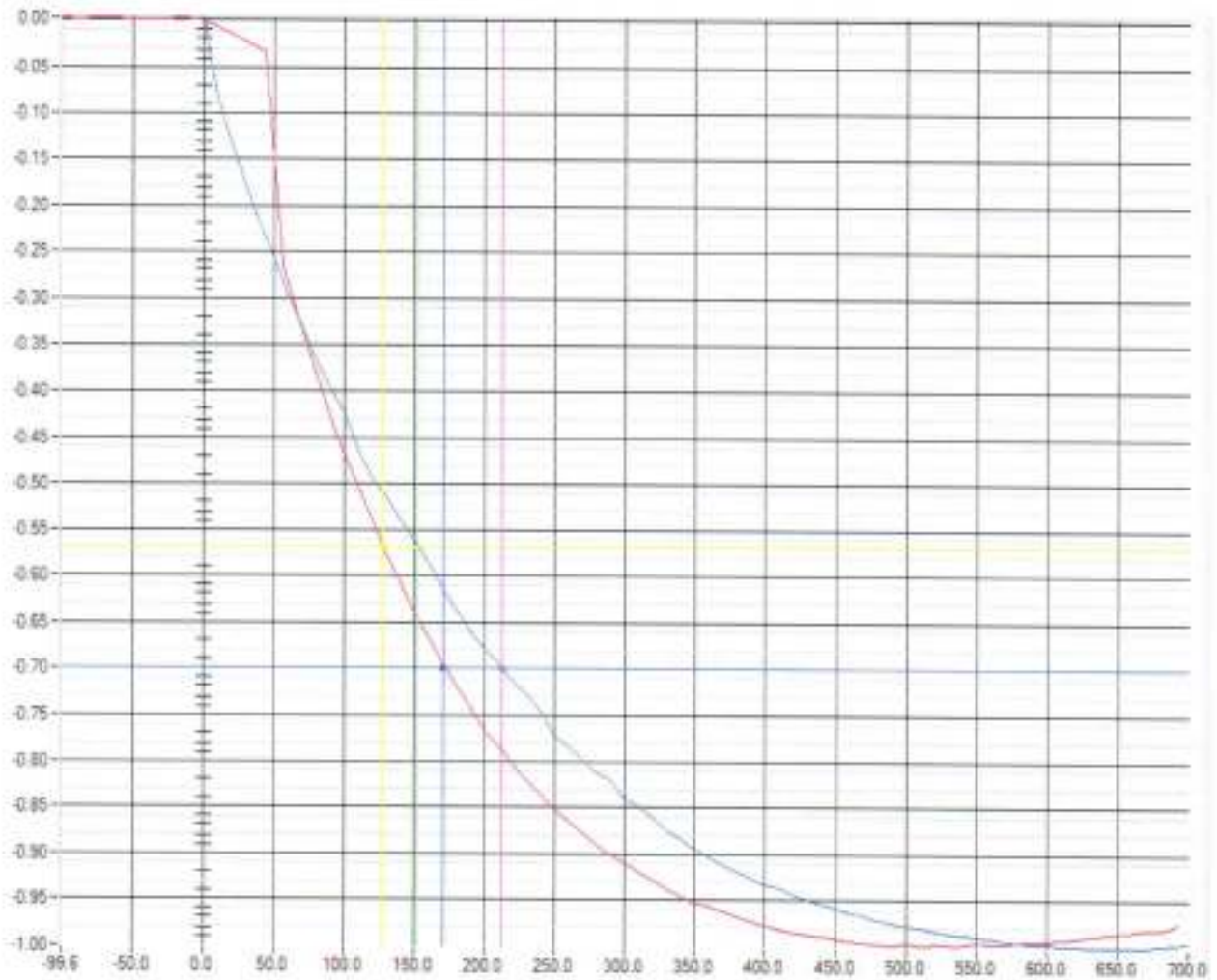

Where:

- On OX axes there is represented time in μs ;
- On OY axes there is represented amplitude U / U_{max} in relative units;
- Red line is the experimental waveform;
- Blue line represents the standard waveform.

$$T_{\text{SRLC}} = 170.92 \mu\text{s}$$

$$T'_{\text{SRLC}} = 214.83 \mu\text{s}$$

$$T_{\text{ESEL}} = 127.25 \mu\text{s}$$

$$T'_{\text{ESEL}} = 150.34 \mu\text{s}$$

$$\Delta T = T'_{\text{SRLC}} - T'_{\text{ESEL}} = 64.49 \mu\text{s}$$



Photo 1



Photo 2



Photo 3

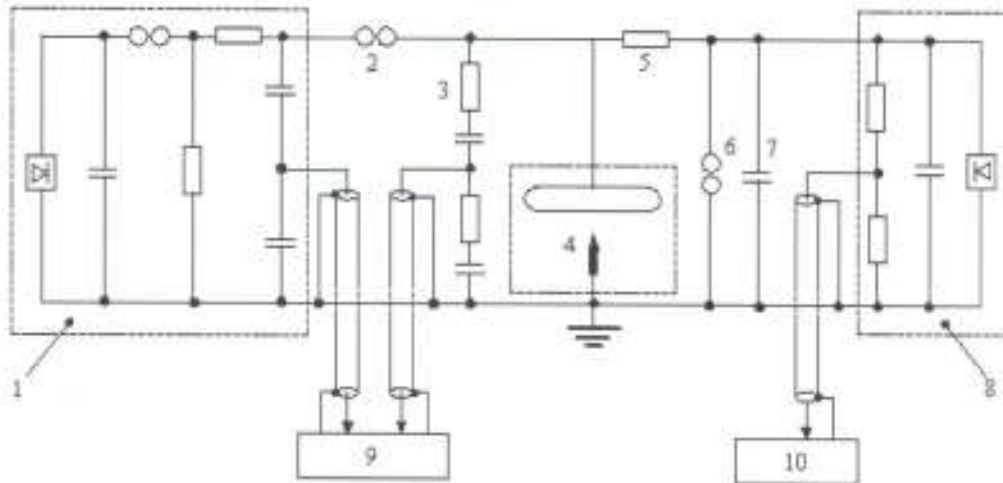

Photo 4



HVD

Test circuit diagram on lightning conductor



- 1 - HV Impulse Generator 4.2Mv-336kWs
- 2 - S serial protective gap, $\phi=230\text{mm}$
- 3 - Damped resistive-capacitive divider, 1400 kV
- 4 - Test configuration
- 5 - Resistance 2M Ω

- 6 - Parallel protective gap, $\phi=500\text{mm}$
- 7 - Capacitor 4.5nF
- 8 - Rectifier cascade GS 1000/30
- 9 - Transient recorder TR-AS 100-10
- 10 - Digital multimeter KETTLER serial no. 1070037



HVD

TEST SET UP ON EARLY STREAMER
EMISSION LIGHTNING CONDUCTOR

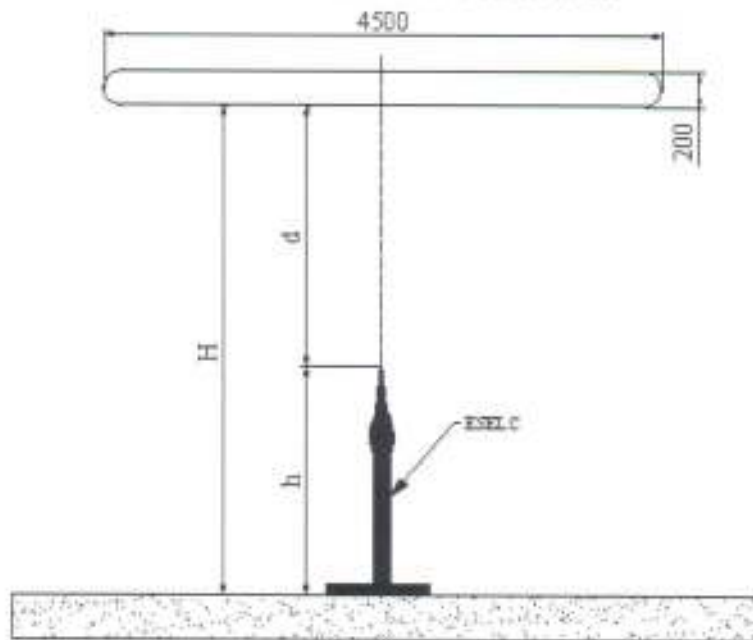



TECHNICAL SPECIFICATIONS

HVD

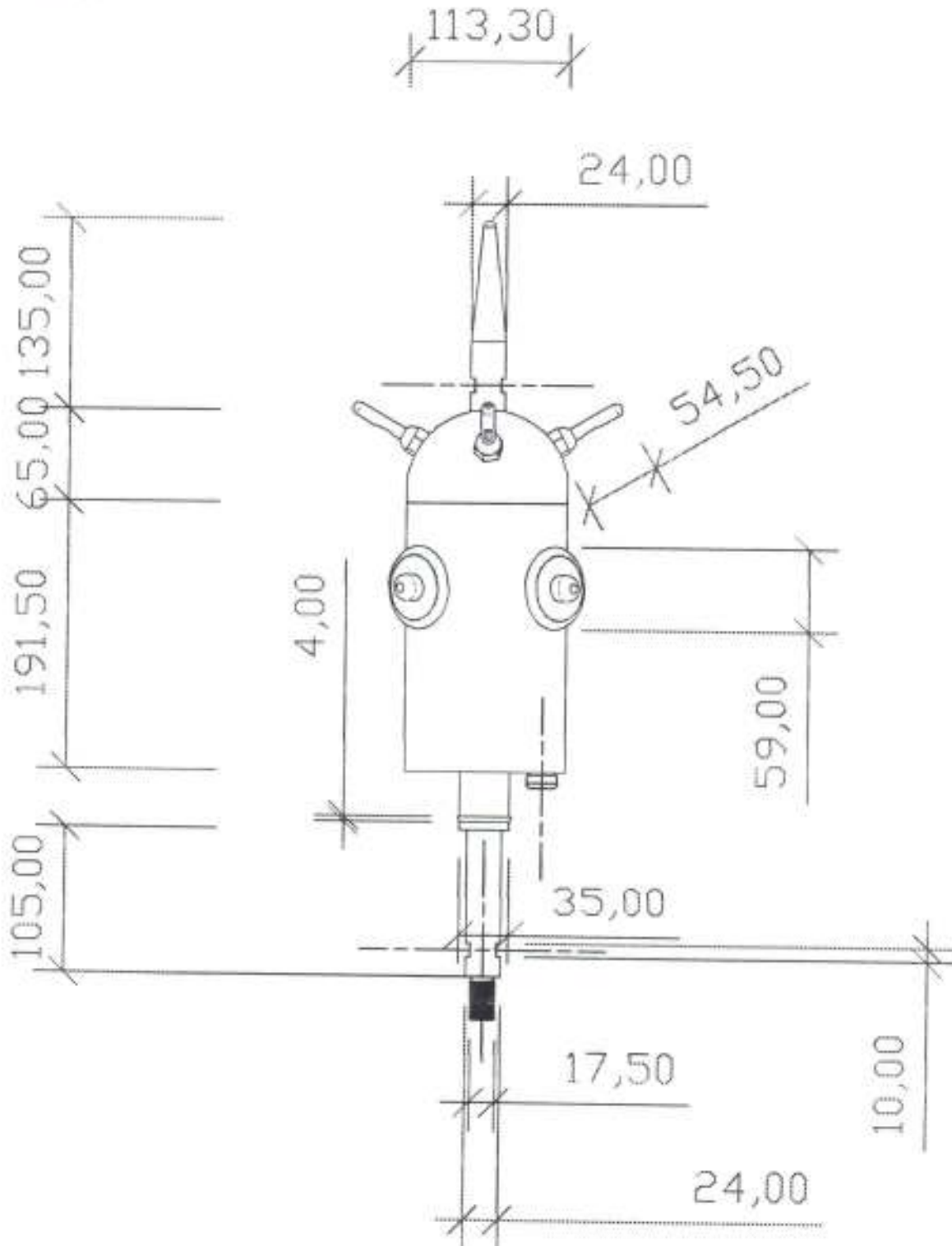

NUMBER	SIGNATURE	DATE	REVISION NUMBER	PART NAME
PREPARED				FOREND EU
CONTROL				
APPROVAL				
PRODUCER				
QUALITY				
			INTERNAL: STAINLESS STEEL 316	UNIT OF MEASURE: mm
				TOLERANCES STATED IN PICTURES: Measure ± 0,1 mm, Angle ± 1°, Surface Roughness: 3,2 µm
				Do Not Measure On Drawing
				DRAWING NO
				Code F-01.09.01(c)
			WEIGHT	SCALE
				PAGE 11

Test protocol

1. Customer: Forend Elektronik ve Dış Tic. A.Ş.
19 Mayıs Mh. Büyükdere Cd. No: 4
34360 Başman Han K: 4 D: 4
Sisli - İstanbul - Turkey

2. Device under test:

Name: Forend Esec / Aktiv Paratoner
Serial Number: FA-00
Manufacturer: Forend A. Ş.
Dimension: Length: 580mm
Maximum diameter: 200mm

3. Demand of test: Lightning current withstand test

4. Realisation of test: The device under test is applied with one current impulse with the waveshape 10/350µs and the peak value of 100kA.

5. Measured results: The parameters of the impulse current are given in following table.

Testsequence: Amp0327				Date: 04/Jul/2003 10:47:19		
3 different ESE devices						
Osc. no.	Peak value	Charge	Specific energy	Risetime	Time to half-value	Time
2	101,5kA	52,0As	2918,0kA ² s	25,2µs	441,9µs	11:35

6. Result: After the impulse current test there is no visible mechanical damage of the housing of the device under test.

7. Photos:

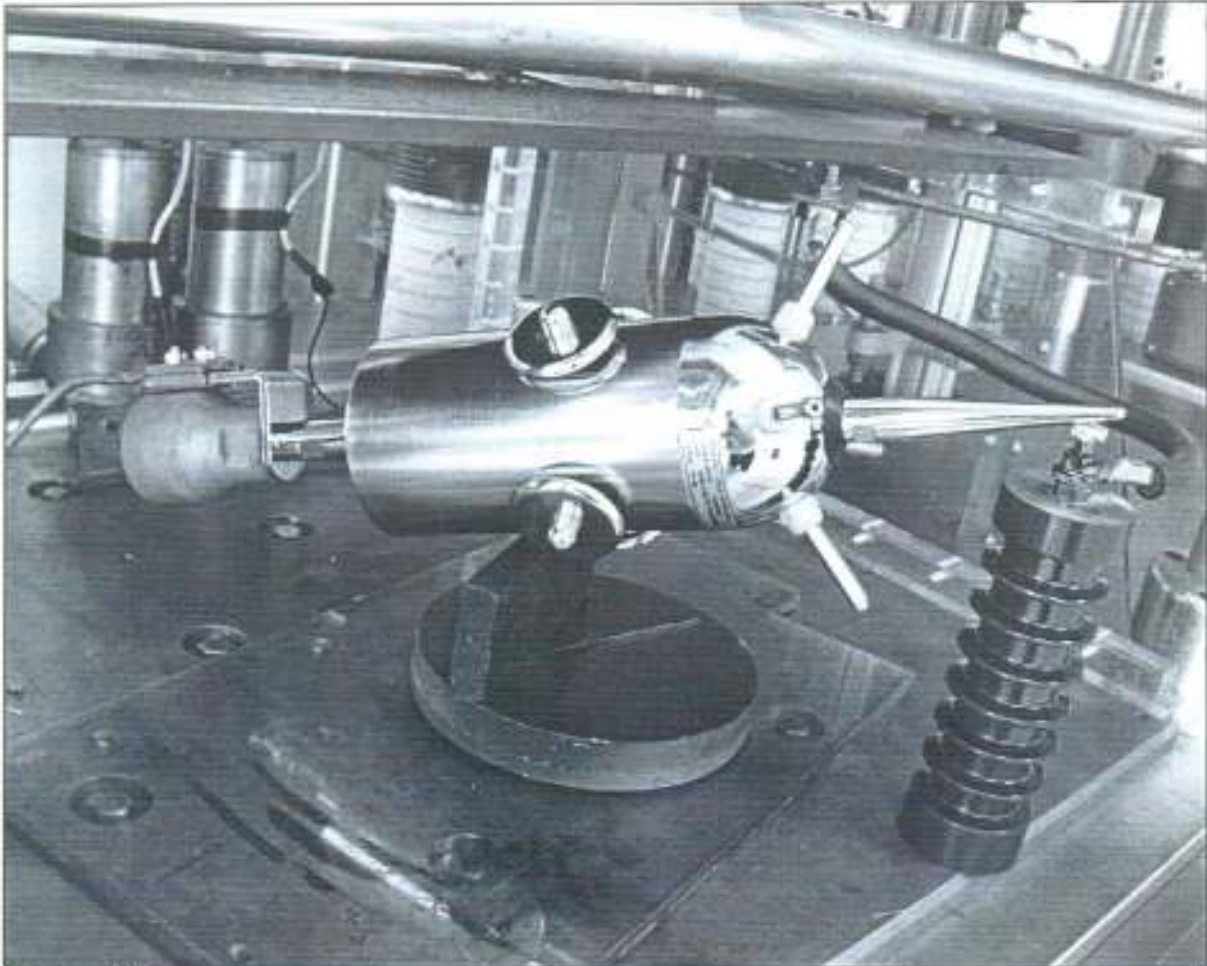

Figure 1: Test arrangement



Figure 2: DUT after the impulse current test

07.07.2003
BET GmbH
Fischkuhle 39
D- 58710 Menden

Test engineer
Dipl.-Ing. M.Benzin

M. Benzin

Prüfsequenz: Amp0327 Aufnahme-Nr.: 2

Impulse Current

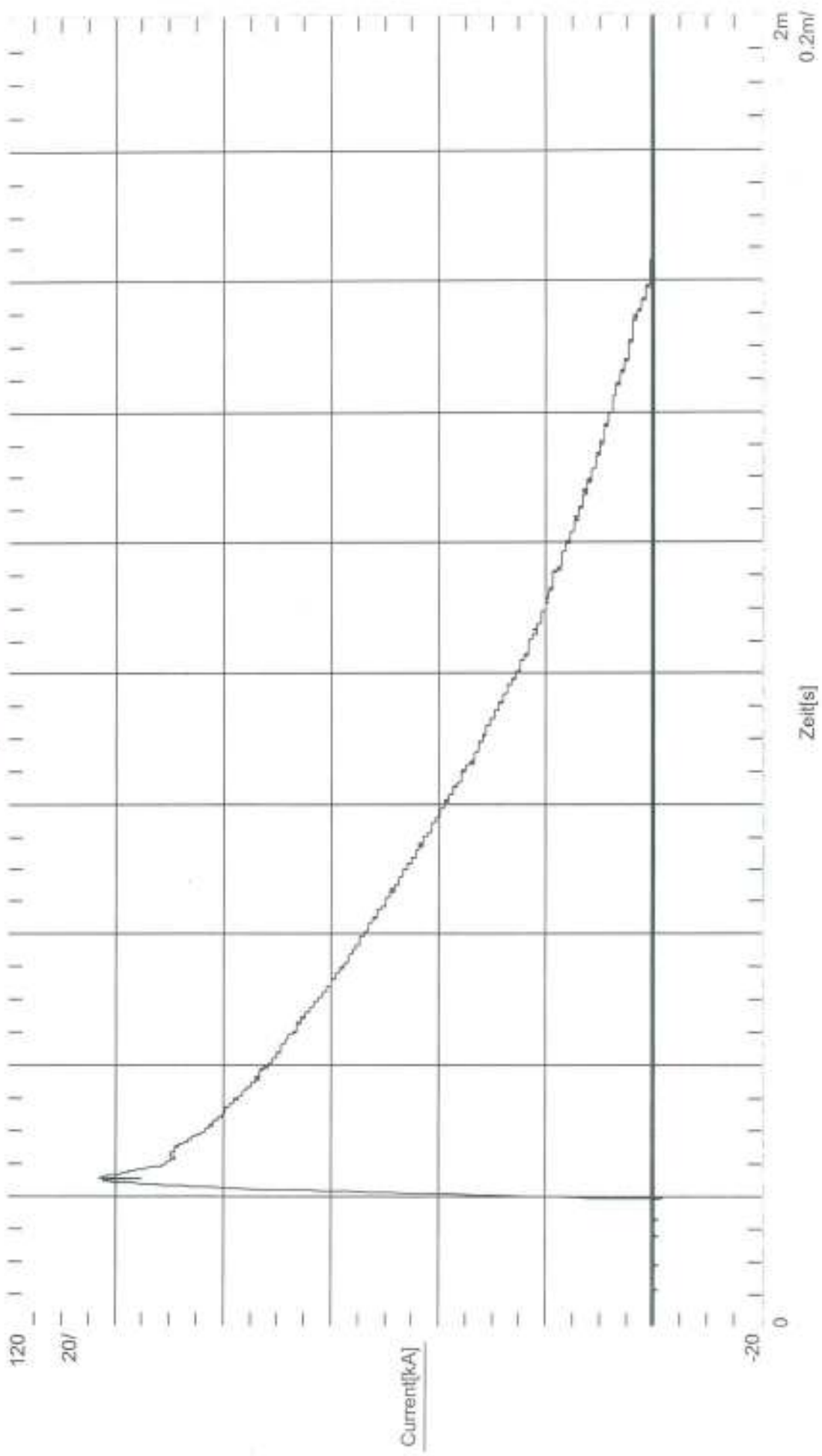

Peakvalue: 101.5kA Risettime: 25.2µs Time to halfvalue : 441.9µs Charge: 52.0As specific Energy: 2918.0kA²s

3 different ESE devices

04/Jul/2003 11:35